

Magnetic Field Navigation in Ants

Yuan Xue, Soso; Tess Tumarkin; Erin McAllester

Reed College Bio342

Do ants (either harvester or carpenter) utilize magnetic cues to navigate either when searching for food or when relocating their dead?

Previous studies have suggested that leaf-cutter ants can navigate by magnetic field orientation, our study observed this capacity in two different species of ants.



http://en.wikipedia.org/wiki/Red_harvester_ant

Camponotus pennsylvanicus (Carpenter ants) are most active at night when they leave their nest to find food and use moist wood as a site in which to tunnel and make their nests.

Pogonomyrmex occidentalis (Harvester ants) are common in the southwestern United States, worker ants seek food and mark their trails with pheromones to help other ants navigate.

Experimental Design:

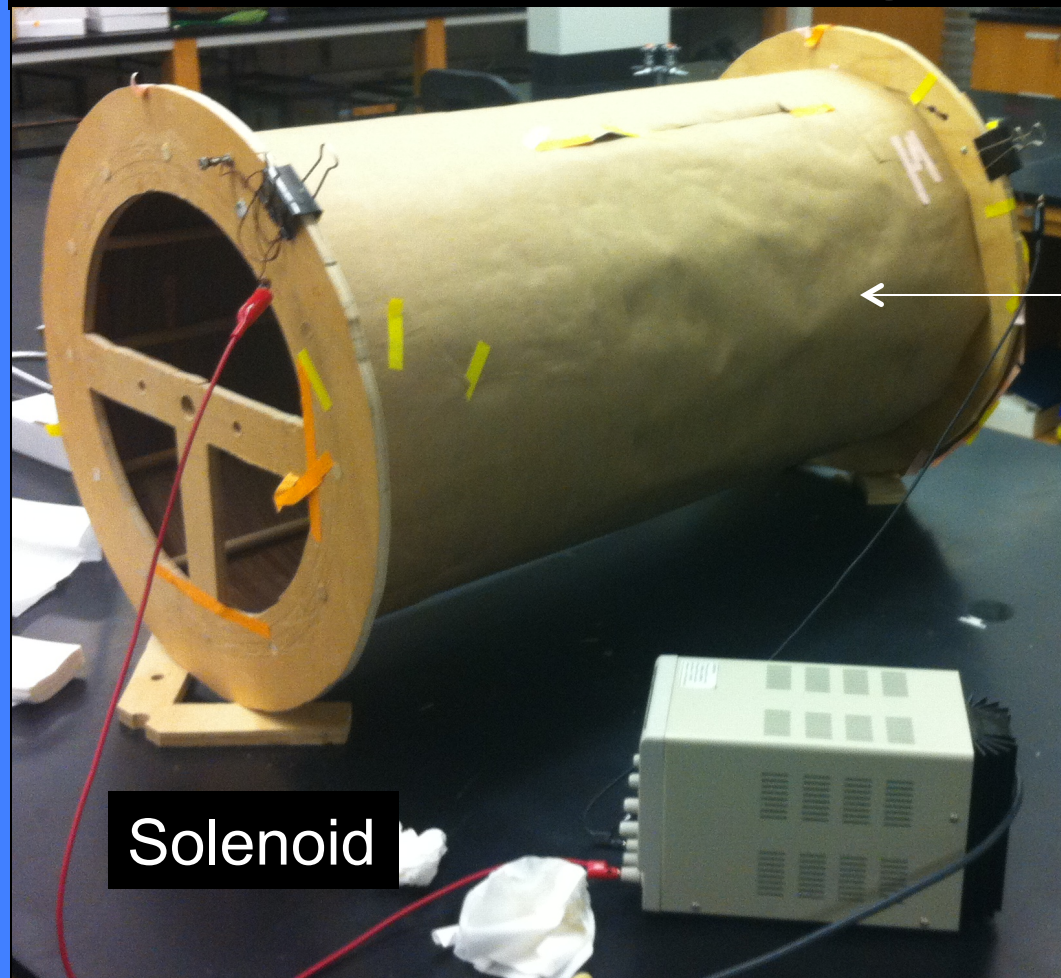

Solenoid wrapped in paper to block visual cues in choice chamber

Solenoid

Choice Chamber (Schematic Top-Bottom View)

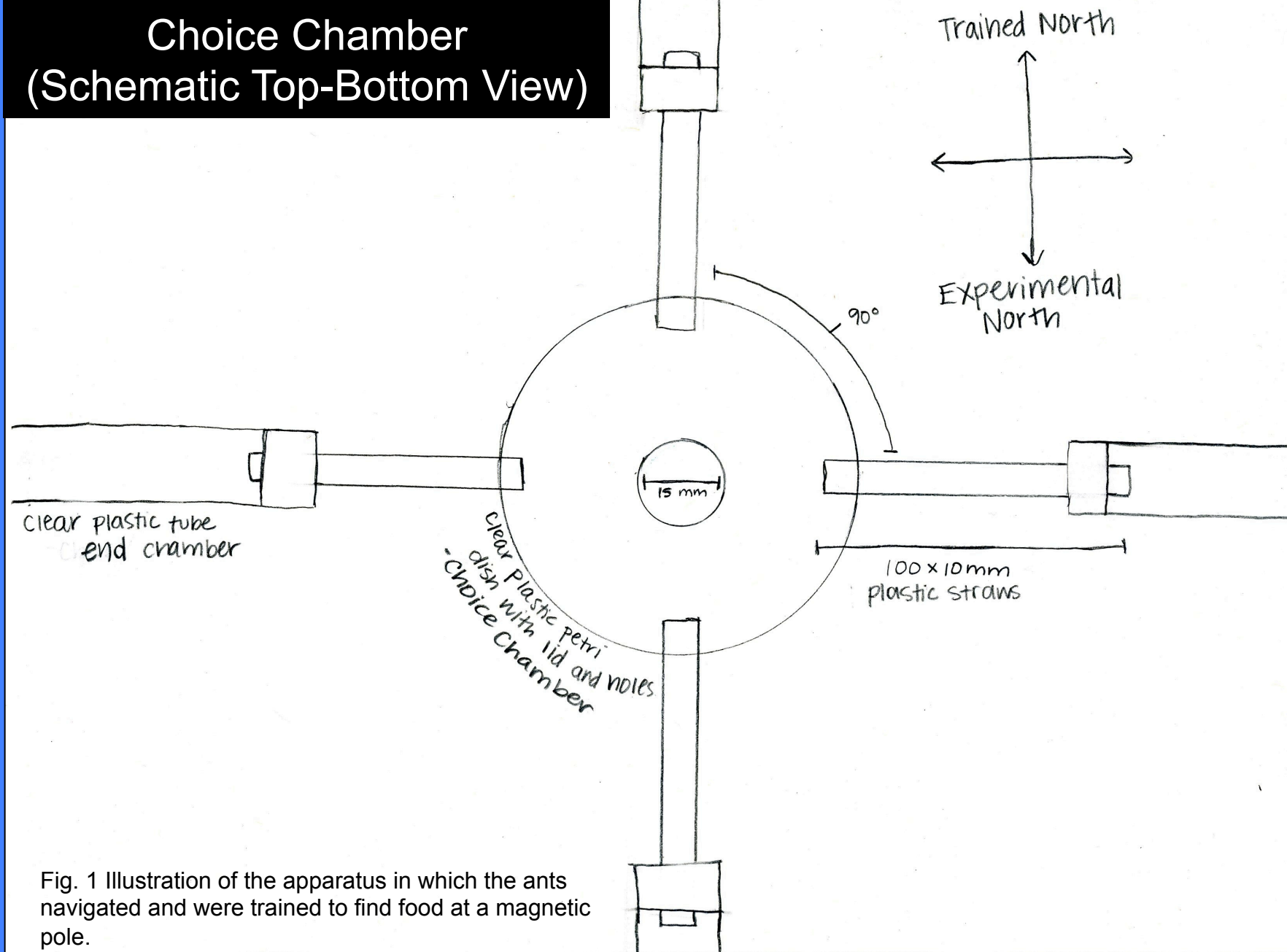

Fig. 1 Illustration of the apparatus in which the ants navigated and were trained to find food at a magnetic pole.



Interior view of the solenoid design and placement of choice chamber



Choice Chamber

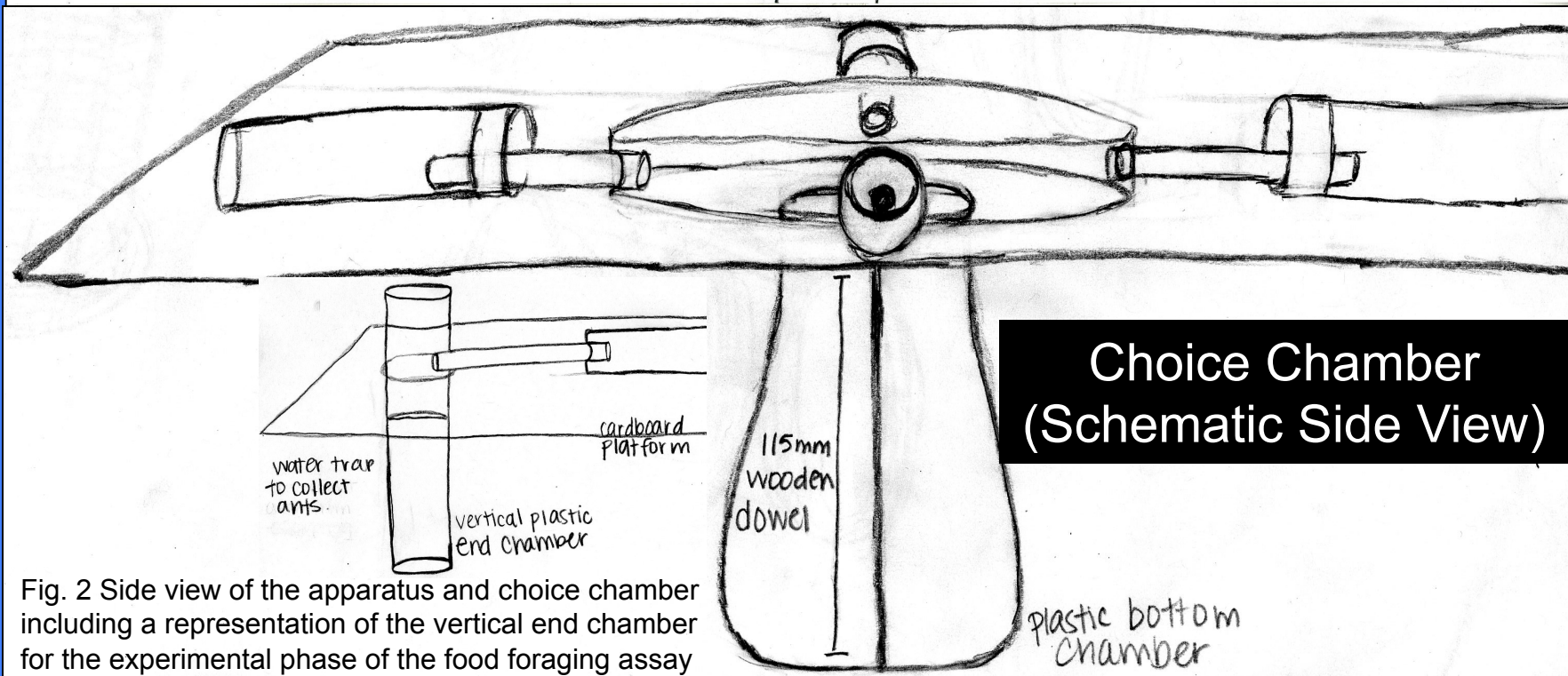

Fig. 2 Side view of the apparatus and choice chamber including a representation of the vertical end chamber for the experimental phase of the food foraging assay

Choice Chamber (Schematic Side View)

Methods

Food Foraging Assay

Training Period: 7 days in choice chamber with food in the trained northern chamber

Experiment: Switch current to experimental north, remove food and pheromone cues by rinsing with 70% EtOH and DI H₂O, put end chamber vertically to capture ants.

Mass Grave Assay

Training Period: Record total number of ant carcasses in each end chamber and note the number of ants alive.

Experiment: Remove dead ants and pheromone cues, switch current to experimental north. Record where the ants move their dead after 75% of the remaining population is dead.

Results

Food Foraging Assay

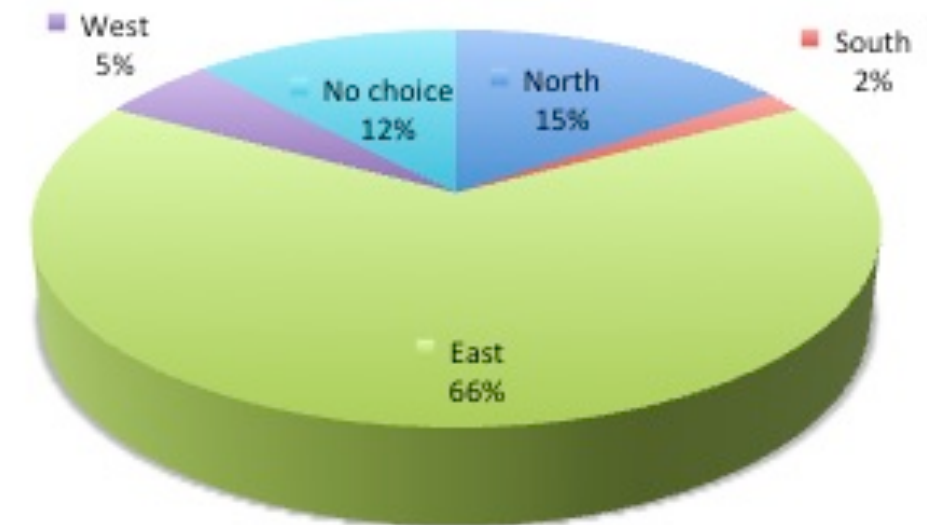

Fig. 3 Results from food foraging assay where ants were trapped in vertical tube and quantified based in their choice of food.

Preliminary Mass Grave Data

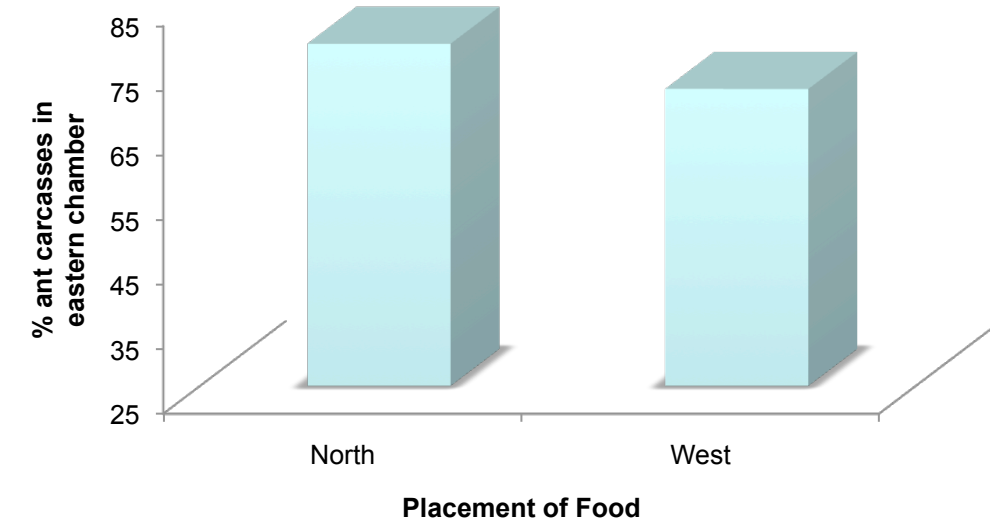

Fig. 4 Ant carcass percentage in eastern chamber before and after food was relocated. Food source was originally placed in the northern chamber and moved to the western chamber after removing dead ants and pheromone cues. This allowed us to minimize food placement as a landmark factor in carpenter ant navigation for disposal of dead.

Conclusion

Our results partially suggest that there is a correlation between magnetic field orientation and the direction to which ants oriented in our behavioral tests. Based on our preliminary results, Carpenter ants moved dead carcasses to the chamber of the same magnetic orientation before and after we cleaned and reassembled the entire choice chamber apparatus; however, it is important to note that for the Carpenter ant mass grave assay, we did not switch the electric current of the solenoid so to alter the orientation of the magnetic field. The result from this assay, although not a strong argument for magnetic field orientation in Carpenters ants, does indicate the ants were able to navigate to the same chamber for disposing carcasses despite absence of visual and chemical cues. Based on results from our food foraging assay conducted on Harvester ants, our data does not suggest that the subjects navigated by a magnetic field as the number of ant subjects that entered into our trained end chamber (north) was not significant. Readers should take caution when interpreting our results, as our study was conducted with a relatively small sample size due to time constraint.

Future Studies

We suggest future studies should be aware of potential experimental flaws, especially those present in our study. Due to spatial constraint, we were unable to place our solenoid and choice chamber apparatus in a dark room. Previous studies have noted that ants are able to navigate by polarized-light, which may affect the results we obtained in this study (Çamiltepe and Stradling, 1995). Additionally, the choice chamber apparatus should be cleaned more frequently (once a day etc.) for future studies to minimize the effects of pheromone trails. As the earth's gravitational field effects the ants navigation and directional choice, future studies should level their apparatus accurately to control for other gravitational cues. Lastly, we were only able to conduct our assays once on each ant group due to a limited time frame. We recommend future studies to conduct the assay with more repetitions and a larger sample size.

References:

- 1) Banks, Alexander N. and Srygley, Robert N. 2003. Orientation by magnetic field in leaf-cutter ants, *Atta colombica* (Hymenoptera: Formicidae). *Ethology*. 109: 835-846.
- 2) Çamiltepe, Yilmaz and Stradling, David J. 1995. Wood Ants Orient to Magnetic Fields. *Proceedings of the Royal Society: Biological Sciences*. 261: 37-41.

Figures

Images: wikipedia.com/wiki/harvesterant
Images of the solenoid taken by Soso Yuan Xue
Figures of choice chamber drawn by Tess Tumarkin

Acknowledgements:

Greg Eibel, Jay Ewing, Suzy Renn, Darrell Schroeter, Lucas Illing, Gene Olson, Kristine Gunter, Jon Kindem, Erin Appleby